

CRF24010

10 W, SiC RF Power MESFET

Cree's CRF24010 is an unmatched silicon carbide (SiC) RF power Metal-Semiconductor Field-Effect Transistor (MESFET). SiC has superior properties compared to silicon or gallium arsenide, including higher breakdown voltage, higher saturated electron drift velocity, and higher thermal conductivity. SiC MESFETs offer greater efficiency, greater power density, and wider bandwidths compared to Si and GaAs transistors.

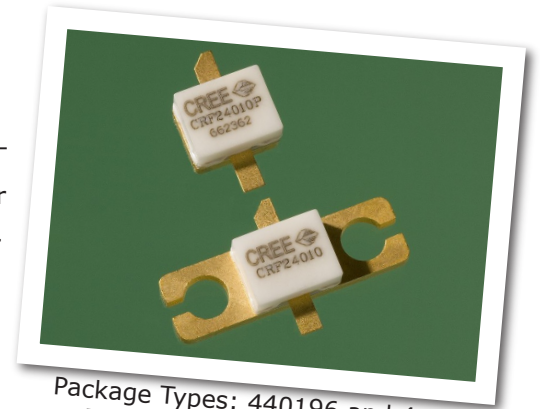

Package Types: 440196 and 440166
PN's: CRF24010P and CRF24010F

FEATURES

- 15 dB Small Signal Gain
- High Efficiency
- 10 W minimum P_{1dB}
- Up to 2700 MHz Operation
- 48 V Operation
- High Breakdown Voltage
- High Temperature Operation

APPLICATIONS

- Wideband Military Communications
- Secure Comms for Homeland Defense
- Class A, A/B Amplifiers
- TDMA, EDGE, CDMA, W-CDMA
- Broadband Amplifiers
- MMDS

Typical Performance

- Drain Efficiency of 45% at 1950 MHz
- IMD -31 dBc at 1950 MHz
- 15 dB Gain at 1950 MHz

Note: Measured in amplifier circuit CRF24010-TB at $V_{DS} = 48$ V, $I_{DQ} = 500$ mA.





Absolute Maximum Ratings (not simultaneous) at 25 °C Case Temperature

Parameter	Symbol	Rating	Units
Drain-source Voltage	V_{DSS}	120	Volts
Gate to source Voltage	V_{GS}	-20, +3	Volts
Storage Temperature	T_{STG}	-55, +150	°C
Operating Junction Temperature	T_J	255	°C
Thermal Resistance, Junction to Case	$R_{\theta JC}$	5.6	°C/W
Soldering Temperature	T_S	225	°C

Electrical Characteristics ($T_C = 25^\circ\text{C}$)

Characteristics	Symbol	Min.	Typ.	Max.	Units	Conditions
DC Characteristics						
Gate Threshold Voltage	$V_{GS(th)}$	-12	-10	-	VDC	$V_{DS} = 10\text{ V}, I_D = 0.5\text{ mA}$
Gate Quiescent Voltage	$V_{GS(Q)}$	-	-9	-	VDC	$V_{DS} = 48\text{ V}, I_D = 400\text{ mA}$
Zero Gate Voltage Drain Current	I_{DSS}	1.2	1.5	1.8	A	$V_{DS} = 10\text{ V}, V_{GS} = 0\text{ V}$
Drain-Source Breakdown Voltage	$V_{(BR)DSS}$	100	-	-	VDC	$V_{GS} = 18, I_D = 10\text{ mA}$
Forward Transconductance	g_m	140	160	-	mS	$V_{DS} = 48\text{ V}, I_D = 250\text{ mA}$
Case Operating Temperature	T_C	-30	-	125	°C	
Screw Torque ¹	T	-	-	60	in-oz	
RF Characteristics						
Gain	G_{SS}	13	15	-	dB	$V_{DD} = 48\text{ V}, I_{DQ} = 500\text{ mA}, f = 1950\text{ MHz}$
Power Output at 1 dB Compression	P_{1dB}	10	12	-	W	$V_{DD} = 48\text{ V}, I_{DQ} = 500\text{ mA}, f = 1950\text{ MHz}$
Power Output at 3 dB Compression	P_{3dB}	15	17	-	W	$V_{DD} = 48\text{ V}, I_{DQ} = 500\text{ mA}, f = 1950\text{ MHz}$
Drain Efficiency ^{2,3}	η	40	45	-	%	$V_{DD} = 48\text{ V}, I_{DQ} = 250\text{ mA}, f = 1950\text{ MHz}$ $P_{OUT} = P_{1dB}$
Intermodulation Distortion	IMD_3	-	-31	-	dBc	$V_{DD} = 48\text{ V}, I_{DQ} = 250\text{ mA}, f_1 = 1950\text{ MHz}, f_2 = 1950.1\text{ MHz}, P_{OUT} = 10\text{ W PEP}$
Minimum Noise Figure	NF_{min}	-	3.1	-	dB	$V_{DD} = 48\text{ V}, I_{DQ} = 500\text{ mA}, f_1 = 1950\text{ MHz}$
Output Mismatch Stress	VSWR	10 : 1	-	-	Ψ	No damage at all phase angles, $V_{DD} = 48\text{ V}, I_{DQ} = 500\text{ mA}, f = 1950\text{ MHz}, P_{OUT} = 10\text{ W CW}$
Dynamic Characteristics						
Input Capacitance	C_{DS}	-	2.5	-	pF	$V_{DS} = 48\text{ V}, V_{GS} = -16\text{ V}, f = 1\text{ MHz}$
Output Capacitance	C_{GS}	-	1.9	-	pF	$V_{DS} = 48\text{ V}, V_{GS} = -16\text{ V}, f = 1\text{ MHz}$
Reverse Transfer Capacitance	C_{GD}	-	0.45	-	pF	$V_{DS} = 48\text{ V}, V_{GS} = -16\text{ V}, f = 1\text{ MHz}$

Notes:

¹ Torque for the 440166 package type.

² Drain Efficiency = P_{OUT} / P_{DC}

³ Power Added Efficiency (PAE) = $(P_{OUT} - P_{IN}) / P_{DC}$



Electrostatic Discharge (ESD) Classifications

Parameter	Symbol	Class	Test Methodology
Human Body Model	HBM	1B	JESD22-A114
Charge Device Model	CDM	C5	JESD22-C101

Broadband Performance ($T_c = 25^\circ\text{C}$, $V_{DS} = 48\text{ V}$, $I_{DQ} = 500\text{ mA}$ in Flange Package)

Swept P1dB and Gain for the CRF24010 in a Broadband Test Fixture

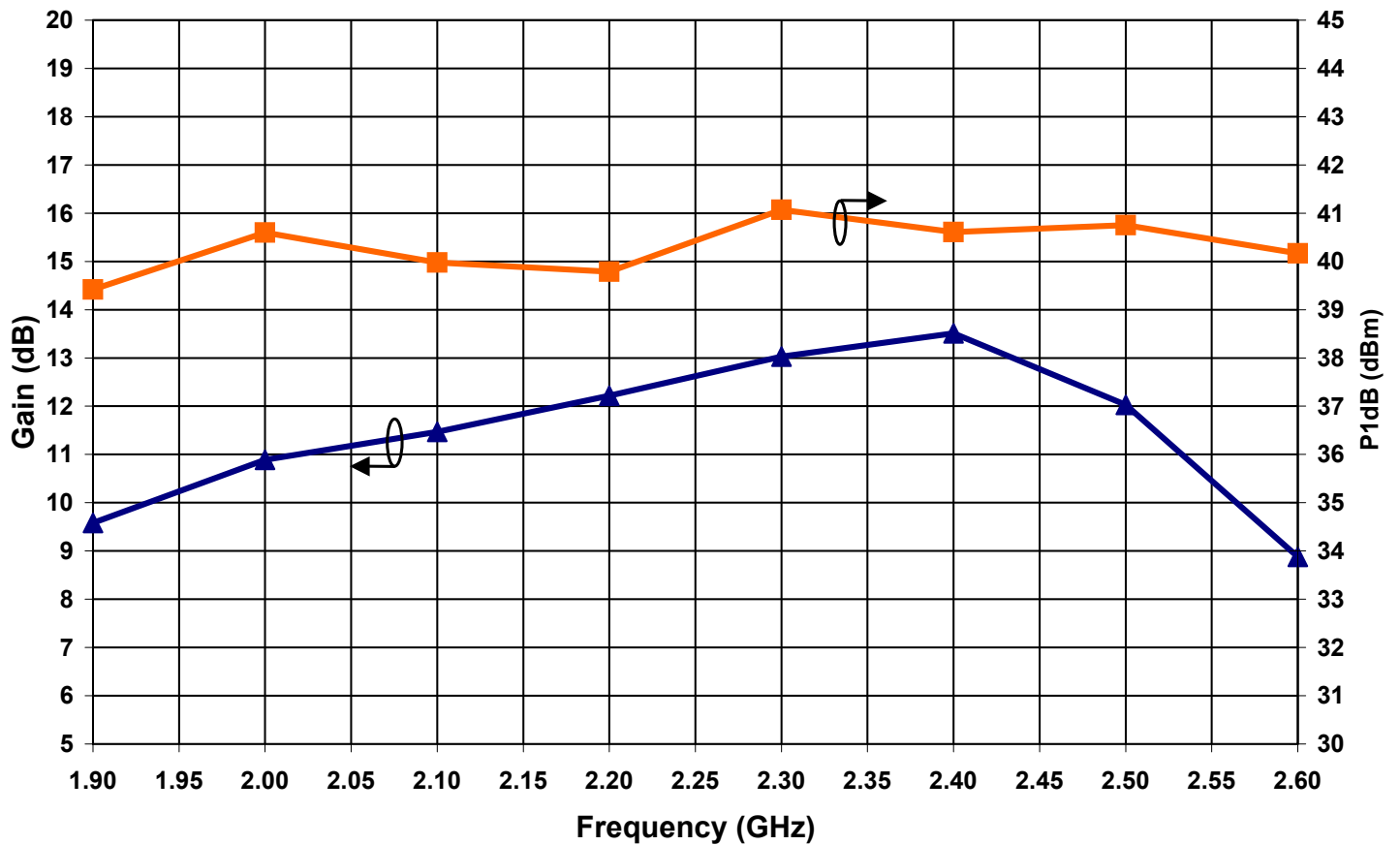

Typical CRF24010-TB Performance ($V_{DS} = 48\text{ V}$, $I_{DQ} = 500\text{ mA}$ in the Flange Package)

Swept CW Data vs Power at 1950 MHz

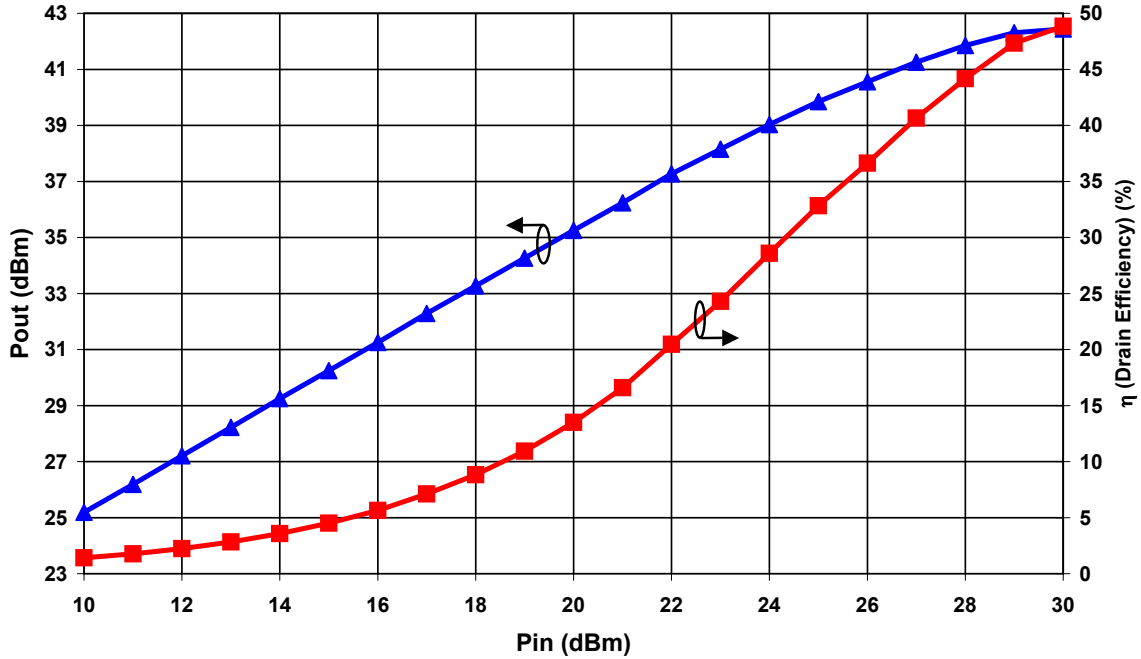

Swept CW Data vs Frequency

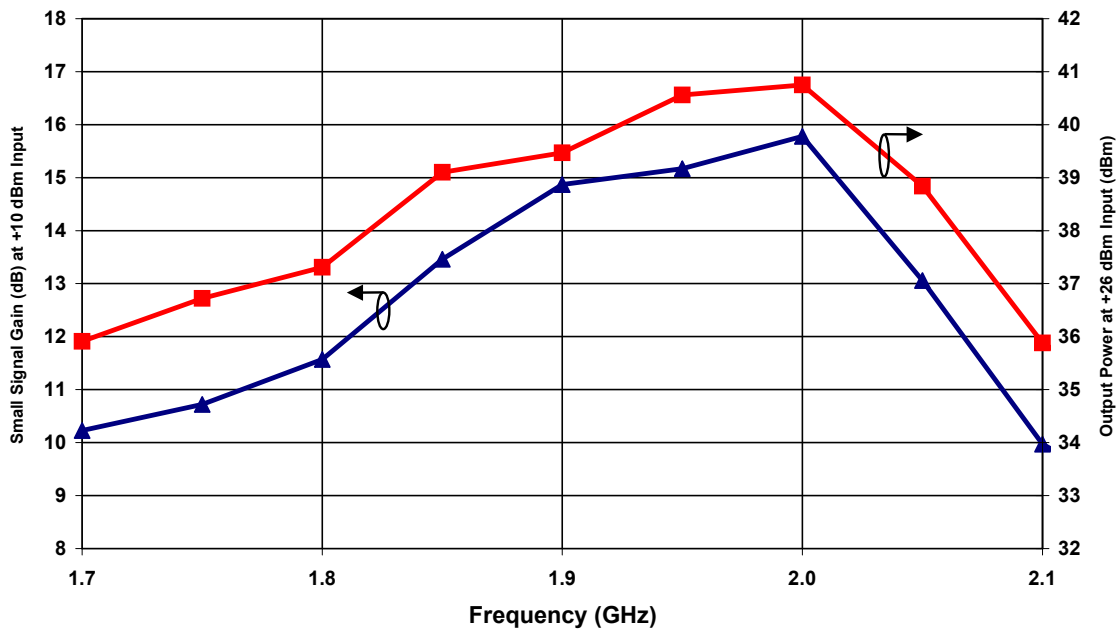



Typical Package S-Parameters
(Small Signal, $V_{DS} = 48\text{ V}$, $I_{DQ} = 250\text{ mA}$, magnitude / angle)

Frequency	S(1,1)	S(2,1)	S(1,2)	S(2,2)
100.0MHz	0.935 / -22.097	7.829 / 165.893	0.024 / 73.361	0.341 / -26.953
200.0MHz	0.920 / -42.676	7.370 / 152.734	0.045 / 62.187	0.356 / -50.854
300.0MHz	0.900 / -60.781	6.758 / 141.088	0.062 / 51.523	0.374 / -70.354
400.0MHz	0.881 / -76.139	6.110 / 131.067	0.074 / 42.232	0.392 / -85.633
500.0MHz	0.865 / -88.933	5.497 / 122.511	0.083 / 34.306	0.407 / -97.471
600.0MHz	0.852 / -99.537	4.950 / 115.167	0.090 / 27.540	0.420 / -106.682
700.0MHz	0.842 / -108.354	4.474 / 108.786	0.095 / 21.708	0.431 / -113.933
800.0MHz	0.834 / -115.739	4.064 / 103.160	0.098 / 16.614	0.441 / -119.725
900.0MHz	0.828 / -121.985	3.712 / 98.128	0.101 / 12.099	0.450 / -124.423
1.000GHz	0.824 / -127.324	3.408 / 93.564	0.103 / 8.043	0.458 / -128.294
1.100GHz	0.821 / -131.937	3.146 / 89.373	0.104 / 4.354	0.466 / -131.533
1.200GHz	0.819 / -135.963	2.917 / 85.485	0.105 / 0.962	0.473 / -134.284
1.300GHz	0.818 / -139.514	2.717 / 81.845	0.106 / -2.188	0.481 / -136.655
1.400GHz	0.818 / -142.674	2.541 / 78.410	0.107 / -5.136	0.488 / -138.729
1.500GHz	0.818 / -145.513	2.385 / 75.148	0.107 / -7.916	0.495 / -140.568
1.600GHz	0.818 / -148.084	2.246 / 72.032	0.107 / -10.553	0.502 / -142.219
1.700GHz	0.818 / -150.432	2.121 / 69.041	0.107 / -13.067	0.509 / -143.721
1.800GHz	0.819 / -152.591	2.009 / 66.159	0.108 / -15.476	0.516 / -145.104
1.900GHz	0.820 / -154.592	1.908 / 63.373	0.108 / -17.792	0.523 / -146.390
2.000GHz	0.821 / -156.457	1.816 / 60.670	0.108 / -20.028	0.530 / -147.598
2.100GHz	0.823 / -158.208	1.733 / 58.043	0.107 / -22.191	0.537 / -148.744
2.200GHz	0.824 / -159.860	1.657 / 55.482	0.107 / -24.290	0.544 / -149.838
2.300GHz	0.826 / -161.428	1.587 / 52.981	0.107 / -26.332	0.550 / -150.892
2.400GHz	0.824 / -162.924	1.523 / 50.536	0.107 / -28.322	0.557 / -151.911
2.500GHz	0.829 / -164.358	1.464 / 48.139	0.107 / -30.265	0.563 / -152.904
2.600GHz	0.831 / -165.738	1.410 / 45.789	0.107 / -32.166	0.569 / -153.875
2.700GHz	0.832 / -167.073	1.360 / 43.479	0.107 / -34.029	0.575 / -154.829
2.800GHz	0.834 / -168.368	1.314 / 41.208	0.106 / -35.856	0.581 / -155.768
2.900GHz	0.836 / -169.630	1.271 / 38.972	0.106 / -37.652	0.587 / -156.696
3.000GHz	0.837 / -170.865	1.231 / 36.767	0.106 / -39.418	0.592 / -157.616
3.100GHz	0.839 / -172.075	1.194 / 34.593	0.106 / -41.158	0.597 / -158.529
3.200GHz	0.841 / -173.266	1.160 / 32.446	0.106 / -42.874	0.602 / -159.437
3.300GHz	0.842 / -174.441	1.127 / 30.323	0.106 / -44.569	0.607 / -160.342
3.400GHz	0.844 / -175.604	1.098 / 28.223	0.106 / -46.244	0.612 / -161.246
3.500GHz	0.845 / -176.757	1.070 / 26.145	0.106 / -47.902	0.616 / -162.148
3.600GHz	0.846 / -177.904	1.044 / 24.085	0.106 / -49.544	0.621 / -163.051
3.700GHz	0.848 / -179.046	1.020 / 22.042	0.106 / -51.173	0.625 / -163.955
3.800GHz	0.849 / 179.813	0.997 / 20.014	0.106 / -52.790	0.628 / -164.862
3.900GHz	0.850 / 178.671	0.976 / 17.999	0.106 / -54.398	0.632 / -165.772
4.000GHz	0.852 / 177.526	0.957 / 15.996	0.106 / -55.998	0.635 / -166.687



Typical Package S-Parameters
(Small Signal, $V_{DS} = 48\text{ V}$, $I_{DQ} = 500\text{ mA}$, magnitude / angle)

Frequency	S(1,1)	S(2,1)	S(1,2)	S(2,2)
100.0MHz	0.933 / -24.697	9.470 / 164.826	0.022 / 72.184	0.281 / -34.171
200.0MHz	0.917 / -47.336	8.814 / 150.896	0.041 / 60.244	0.311 / -62.220
300.0MHz	0.898 / -66.755	7.970 / 138.866	0.055 / 49.176	0.344 / -83.098
400.0MHz	0.881 / -82.780	7.113 / 128.773	0.066 / 39.787	0.372 / -98.337
500.0MHz	0.867 / -95.802	6.332 / 120.339	0.073 / 31.953	0.394 / -109.583
600.0MHz	0.856 / -106.375	5.654 / 113.216	0.078 / 25.378	0.411 / -118.050
700.0MHz	0.847 / -115.027	5.079 / 107.100	0.082 / 19.781	0.425 / -124.563
800.0MHz	0.841 / -122.187	4.592 / 101.752	0.084 / 14.932	0.436 / -129.678
900.0MHz	0.837 / -128.190	4.179 / 96.993	0.086 / 10.659	0.445 / -133.774
1.000GHz	0.834 / -133.288	3.828 / 92.961	0.088 / 6.834	0.454 / -137.115
1.100GHz	0.831 / -137.674	3.526 / 88.750	0.089 / 3.362	0.462 / -139.886
1.200GHz	0.830 / -141.491	3.266 / 85.096	0.090 / 0.172	0.469 / -142.221
1.300GHz	0.829 / -144.852	3.039 / 81.675	0.090 / -2.790	0.475 / -144.221
1.400GHz	0.829 / -147.841	2.840 / 78.445	0.091 / -5.564	0.482 / -145.960
1.500GHz	0.828 / -150.526	2.665 / 75.375	0.091 / -8.183	0.488 / -147.492
1.600GHz	0.829 / -152.959	2.509 / 72.440	0.091 / -10.671	0.495 / -148.863
1.700GHz	0.829 / -155.183	2.370 / 69.618	0.091 / -13.047	0.501 / -150.104
1.800GHz	0.830 / -157.231	2.246 / 66.896	0.091 / -15.328	0.507 / -151.244
1.900GHz	0.830 / -159.132	2.133 / 64.258	0.091 / -17.526	0.513 / -152.301
2.000GHz	0.831 / -160.907	2.032 / 61.696	0.091 / -19.652	0.519 / -153.294
2.100GHz	0.832 / -162.576	1.940 / 59.200	0.091 / -21.714	0.525 / -154.235
2.200GHz	0.833 / -164.155	1.855 / 56.763	0.091 / -23.720	0.530 / -155.136
2.300GHz	0.834 / -165.657	1.778 / 54.379	0.091 / -25.676	0.536 / -156.004
2.400GHz	0.836 / -167.092	1.708 / 52.042	0.091 / -27.587	0.542 / -156.847
2.500GHz	0.837 / -168.471	1.643 / 49.748	0.091 / -29.458	0.547 / -157.670
2.600GHz	0.838 / -169.802	1.583 / 47.492	0.091 / -31.294	0.552 / -158.479
2.700GHz	0.839 / -171.093	1.528 / 45.273	0.091 / -33.096	0.558 / -159.277
2.800GHz	0.840 / -172.348	1.477 / 43.085	0.091 / -34.870	0.563 / -160.067
2.900GHz	0.842 / -173.575	1.430 / 40.926	0.091 / -36.616	0.568 / -160.852
3.000GHz	0.843 / -174.777	1.386 / 38.795	0.091 / -38.340	0.572 / -161.634
3.100GHz	0.844 / -175.960	1.346 / 36.687	0.091 / -40.041	0.577 / -162.415
3.200GHz	0.845 / -177.126	1.308 / 34.602	0.091 / -41.724	0.581 / -163.197
3.300GHz	0.846 / -178.281	1.273 / 32.537	0.091 / -43.390	0.586 / -163.981
3.400GHz	0.848 / -179.426	1.240 / 30.490	0.091 / -45.041	0.590 / -164.768
3.500GHz	0.849 / 179.435	1.210 / 28.259	0.091 / -46.679	0.594 / -165.559
3.600GHz	0.850 / 178.299	1.181 / 26.443	0.091 / -48.306	0.597 / -166.355
3.700GHz	0.851 / 177.164	1.155 / 24.440	0.091 / -49.924	0.601 / -167.157
3.800GHz	0.852 / 176.027	1.130 / 22.447	0.091 / -51.534	0.604 / -167.96
3.900GHz	0.853 / 174.886	1.107 / 20.464	0.091 / -53.138	0.607 / -168.783
4.000GHz	0.853 / 173.738	1.086 / 18.489	0.091 / -54.738	0.610 / -169.607

CRF24010-TB Demonstration Test Fixture

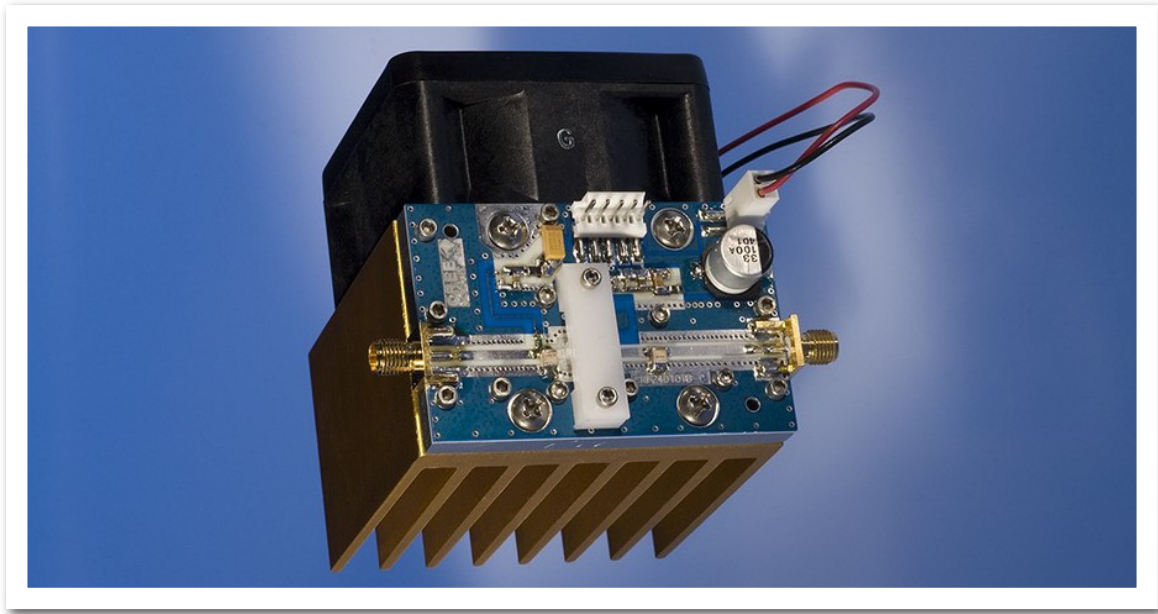

CRF24010-TB Demonstration Test Fixture Diagram

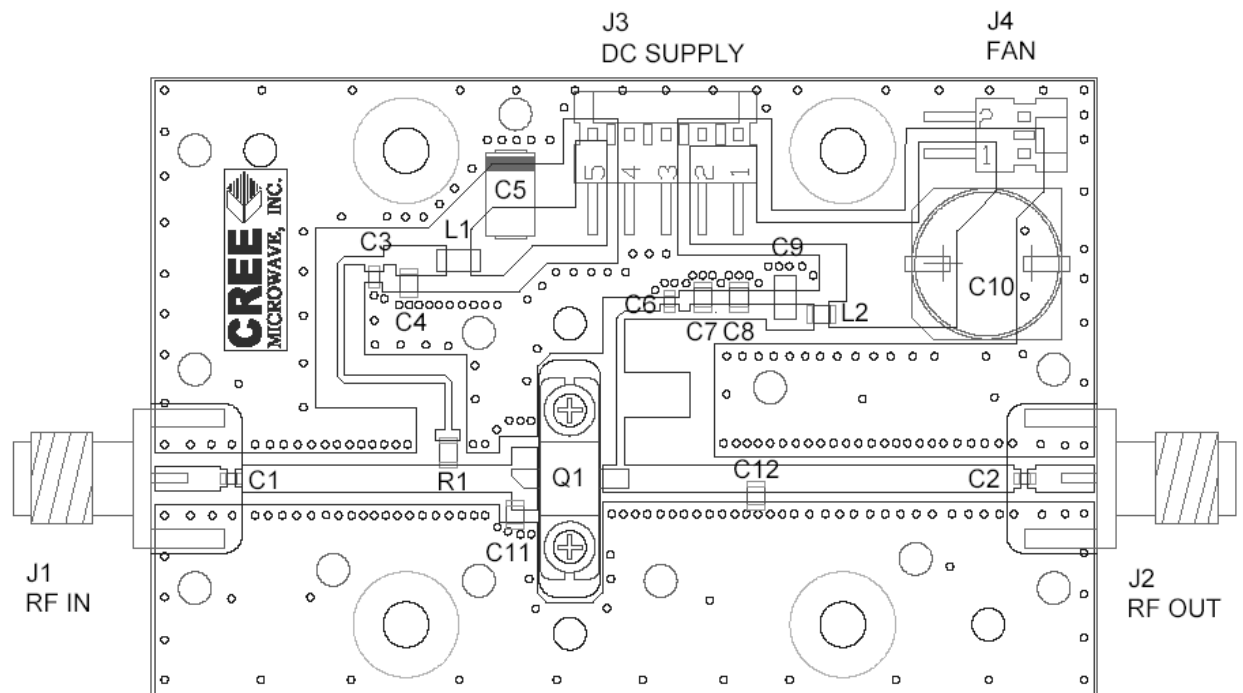

CRF24010-TB Demonstration Test Fixture Schematic

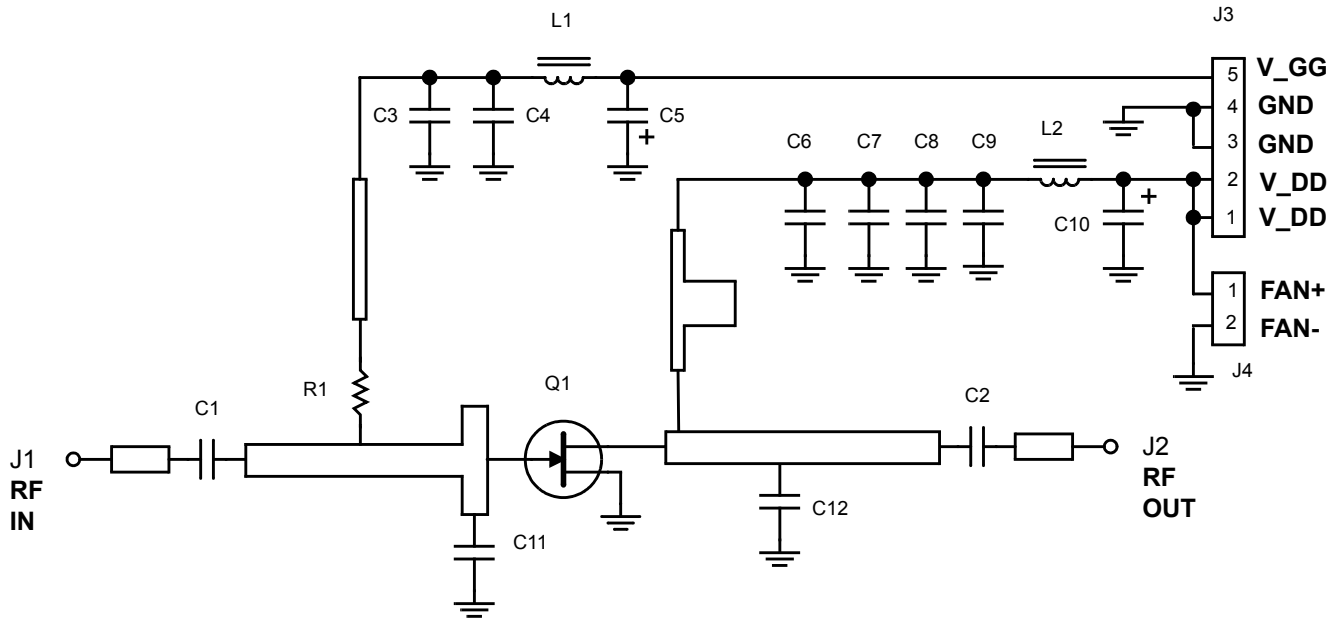

CRF24010-TB Demonstration Test Fixture Bill of Materials

Designator	Description	Qty
C1,C2,C3,C6	CAP, 27pF, 0603, ATC600S270JW250XT	4
C4	CAP, 0.1uF, 25V, 0805, CERAMIC	1
C5	CAP, 10uF, 25V, TANTALUM	1
C7	CAP, 2.2nF, 100V, AVX08051C222MAT2A	1
C8	CAP, 10nF, 100V, 0805, CERAMIC	1
C9	CAP, 0.1uF, 100V, 1206 CERAMIC	1
C10	CAP, 33uF, 100V, ALUMINUM ELECTROLYTIC	1
C11	CAP, 3.9pF, 150V, PORCELAIN, ATC-100B3R9OBW500X	1
C12	CAP, 2.4pF, 150V, PORCELAIN, ATC-100B2R4OBW500X	1
R1	RES, 39 OHM, 0.1W, 0805	1
L1	FERRITE, 80 OHM, STEWARD HI1206K101R	1
L2	FERRITE, MURATA BLM21P220SG	1
J1,J2	CONNECTOR, SMA, FLANGE MOUNT, FEMALE	2
J3	CONNECTOR, MOLEX, 5-PIN, MALE	1
J4	CONNECTOR, MOLEX, 2-PIN, MALE	1
Q1	CRF24010	1

Note: Some values may differ due to substitution in the event of temporarily unavailable parts.

Product Dimensions - CRF24010P (Package Type — 440196)

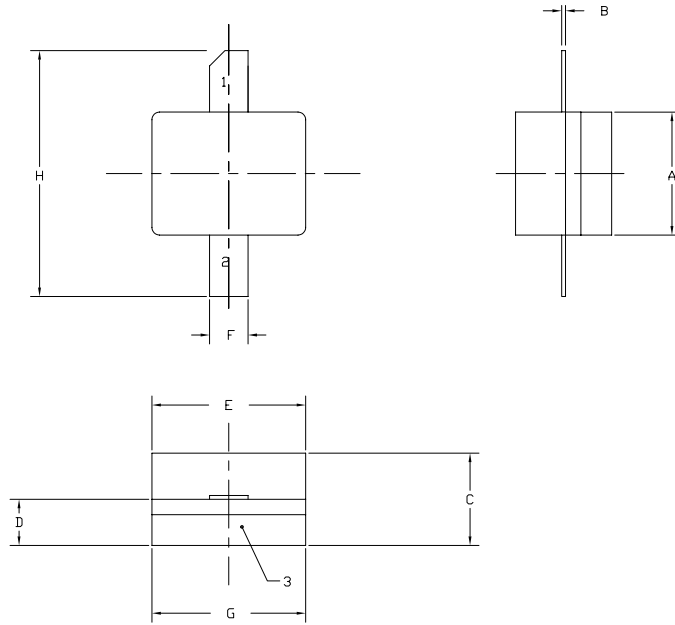

NOTES:

1. DIMENSIONING AND TOLERANCING PER ANSI Y14.5M, 1982.
2. CONTROLLING DIMENSION: INCH.
3. ADHESIVE FROM LID MAY EXTEND A MAXIMUM OF 0.020" BEYOND EDGE OF LID.
4. LID MAY BE MISALIGNED TO THE BODY OF THE PACKAGE BY A MAXIMUM OF 0.008" IN ANY DIRECTION.
5. ALL PLATED SURFACES ARE NI/AU.

DIM	INCHES		MILLIMETERS	
	MIN	MAX	MIN	MAX
A	0.155	0.165	3.94	4.19
B	0.003	0.006	0.10	0.15
C	0.115	0.135	2.92	3.17
D	0.057	0.067	1.45	1.70
E	0.195	0.205	4.95	5.21
F	0.045	0.055	1.14	1.40
G	0.195	0.205	4.95	5.21
H	0.280	0.360	7.112	9.114

- PIN 1. GATE
 PIN 2. DRAIN
 PIN 3. SOURCE

Product Dimensions - CRF24010F (Package Type — 440166)

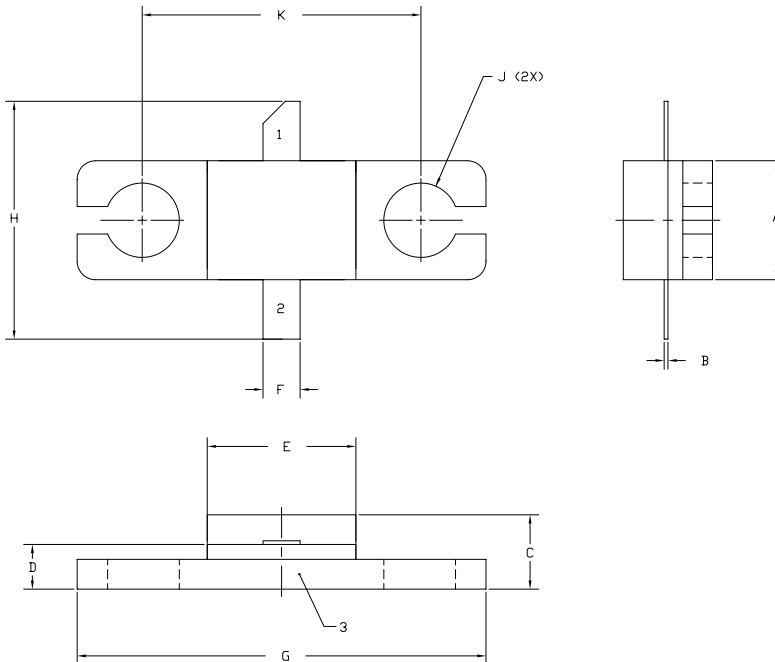

NOTES:

1. DIMENSIONING AND TOLERANCING PER ANSI Y14.5M, 1982.
2. CONTROLLING DIMENSION: INCH.
3. ADHESIVE FROM LID MAY EXTEND A MAXIMUM OF 0.020" BEYOND EDGE OF LID.
4. LID MAY BE MISALIGNED TO THE BODY OF THE PACKAGE BY A MAXIMUM OF 0.008" IN ANY DIRECTION.
5. ALL PLATED SURFACES ARE NI/AU.

DIM	INCHES		MILLIMETERS	
	MIN	MAX	MIN	MAX
A	0.155	0.165	3.94	4.19
B	0.004	0.006	0.10	0.15
C	0.115	0.135	2.92	3.43
D	0.057	0.067	1.45	1.70
E	0.195	0.205	4.95	5.21
F	0.045	0.055	1.14	1.40
G	0.545	0.555	13.84	14.09
H	0.280	0.360	7.87	8.38
J	ø .100		2.54	
K	0.375		9.53	

- PIN 1. GATE
 PIN 2. DRAIN
 PIN 3. SOURCE



Disclaimer

Specifications are subject to change without notice. Cree, Inc. believes the information contained within this data sheet to be accurate and reliable. However, no responsibility is assumed by Cree for any infringement of patents or other rights of third parties which may result from its use. No license is granted by implication or otherwise under any patent or patent rights of Cree. Cree makes no warranty, representation or guarantee regarding the suitability of its products for any particular purpose. "Typical" parameters are the average values expected by Cree in large quantities and are provided for information purposes only. These values can and do vary in different applications, and actual performance can vary over time. All operating parameters should be validated by customer's technical experts for each application. Cree products are not designed, intended, or authorized for use as components in applications intended for surgical implant into the body or to support or sustain life, in applications in which the failure of the Cree product could result in personal injury or death, or in applications for planning, construction, maintenance or direct operation of a nuclear facility. Cree and the Cree logo are registered trademarks of Cree, Inc.

For more information, please contact:

Cree, Inc.
4600 Silicon Drive
Durham, NC 27703
www.cree.com/wireless

Ryan Baker
Cree, Marketing
919.287.7816

Tom Dekker
Cree, Sales Director
919.313.5639